

HORIZON HEIGHTS BUILDING 5P CONDOMINIUMS

LOCATED IN THE SOUTHEAST QUARTER
OF SECTION 36,
TOWNSHIP 3 SOUTH, RANGE 2 WEST,
SALT LAKE BASE AND MERIDIAN

SURVEYOR CERTIFICATE

In accordance with Section 10-9A-603 of the Utah Code, I, Nathan B. Weber, do hereby certify that I am a Professional Land Surveyor holding license number 5152762 in accordance with Title 58, Chapter 22 of the Professional Engineers and Professional Land Surveyors Licensing Act.

I further certify that on behalf of Diamond Land Surveying, LLC, I have completed a survey of the property described on the plat in accordance with Section 17-23-17 of Utah Code, and have verified all measurements, shown and have subdivided said property into lots and streets hereafter to be known as HORIZON HEIGHTS BUILDING 5P CONDOMINIUMS, and have placed monuments as represented on the plat.

BOUNDARY DESCRIPTION

A parcel of land located in the Southeast Quarter of Section 36, Township 3 South, Range 2 West, Salt Lake Base and Meridian described as follows:

Beginning at a point North 89°37'15" West 1490.40 feet along the Section Line and South 0°22'45" West 55.36 feet from the East Quarter Corner of Section 36, Township 3 South, Range 2 West, Salt Lake Base and Meridian and running:

thence South 89°24'57" East 78.09 feet to the westerly right-of-way line of Tortola Edge Drive;

thence South 0°35'03" West 146.67 feet along the said westerly right-of-way line;

thence North 89°24'57" West 77.64 feet;

thence North 0°24'37" East 146.67 feet to the point of beginning.

OWNER'S DEDICATION

Know all men by these presents that the undersigned owners of the hereon described tract of land, hereby set apart and subdivide the same into lots and streets as shown on this plat and name said plat

HORIZON HEIGHTS BUILDING 5P CONDOMINIUMS

and do hereby dedicate for perpetual use of the public all, street right-of-ways, lots and easements as shown on this plat as intended for Public use. Owners hereby agree to warrant and defend and save the City harmless against any easements or other encumbrance on a dedicated street which will interfere with the City's use, maintenance and operation of the street.

Steven Maddox
Edge Horizon Heights, LLC

2-2-17
Date

CONSENT TO DEDICATE

Know all men by these presents that the undersigned, being the Trustee under a Trust Deed of the real property described on the description at left and, having caused same to be subdivided into lots and/or public streets to be hereafter known as HORIZON HEIGHTS BUILDING 5P CONDOMINIUMS, does hereby dedicate for perpetual use of the public all parcels of land shown on this plat as intended for Public use.

Date

ACKNOWLEDGMENT

STATE OF UTAH)
):S.S.
COUNTY OF SALT LAKE)

ON THIS THE 2 DAY OF February 2017, PERSONALLY APPEARED BEFORE ME, Steven Maddox, THE SIGNER OF THE FOREGOING INSTRUMENT, WHO DULY ACKNOWLEDGED TO ME THAT (S)HE IS A Manager OF EDGE HORIZON HEIGHTS, LLC, A UTAH LIMITED LIABILITY COMPANY, AND IS AUTHORIZED TO EXECUTE THE FOREGOING AGREEMENT IN ITS BEHALF AND THAT HE OR SHE EXECUTED IT IN SUCH CAPACITY.

MICHELLE L. HOLT
NOTARY PUBLIC-STATE OF UTAH
COMMISSION# 690083
COMM. EXP. 07-01-2020

Michelle Holt
NOTARY PUBLIC
RESIDING AT: Springville, UT

ROCKY MOUNTAIN POWER STATEMENT

1. Pursuant to Utah Code Ann. § 54-3-27 this plat conveys to the owner(s) or operators of utility facilities a public utility easement along with all the rights and duties described therein.

2. Pursuant to Utah Code Ann. § 17-27a-603(4)(c)(ii) Rocky Mountain Power accepts delivery of the PUE as described in this plat and approves this plat solely for the purpose of confirming that the plat contains public utility easements and approximates the location of the public utility easements, but does not warrant their precise location. Rocky Mountain Power may require other easements in order to serve this development. This approval does not affect any right that Rocky Mountain Power has under:

- (1) a recorded easement or right-of way
- (2) the law applicable to prescriptive rights
- (3) Title 54, Chapter 8a, Damage to Underground Utility Facilities or
- (4) any other provision of law.

SOUTH VALLEY SEWER DISTRICT STATEMENT

THE SIGNATURE OF SOUTH VALLEY SEWER DISTRICT ON THIS PLAT DOES NOT CONSTITUTE ANY GUARANTEE OF AVAILABILITY OF SANITARY SEWER TO THE PROPERTY OR ANY APPROVAL OF SEWER LINE FACILITIES. THE OWNER(S) OF THE PROPERTY MUST PROVIDE SATISFACTORY PLANS TO THE SEWER DISTRICT FOR REVIEW AND APPROVAL BEFORE CONNECTING TO THE DISTRICT'S SEWER SYSTEM AND WILL BE REQUIRED TO COMPLY WITH THE DISTRICT'S RULES AND REGULATIONS.

ACKNOWLEDGMENT

STATE OF UTAH)
):S.S.
COUNTY OF SALT LAKE)

ON THIS THE _____ DAY OF _____, 2016, PERSONALLY APPEARED BEFORE ME, _____, THE SIGNER OF THE FOREGOING INSTRUMENT, WHO DULY ACKNOWLEDGED TO ME THAT (S)HE IS THE _____ OF THE _____ AND THAT THE FOREGOING INSTRUMENT WAS SIGNED ON BEHALF OF SAID CORPORATION, AND SAID _____ ACKNOWLEDGED TO ME THAT SAID CORPORATION EXECUTED THE SAME.

NOTARY PUBLIC
RESIDING AT:

ACKNOWLEDGMENT

STATE OF UTAH)
):S.S.
COUNTY OF SALT LAKE)

ON THIS THE _____ DAY OF _____, 2016, PERSONALLY APPEARED BEFORE ME, _____, THE SIGNER OF THE FOREGOING INSTRUMENT, WHO DULY ACKNOWLEDGED TO ME THAT (S)HE IS THE _____ OF THE _____ AND THAT THE FOREGOING INSTRUMENT WAS SIGNED ON BEHALF OF SAID CORPORATION, AND SAID _____ ACKNOWLEDGED TO ME THAT SAID CORPORATION EXECUTED THE SAME.

NOTARY PUBLIC
RESIDING AT:

"Each unit depicted on this plat and contained within a common building is served by a common sewer lateral. Any sewer lateral extending outside the boundaries of any unit depicted on this plat shall be deemed "common area" and shall be operated and maintained by the HOA"

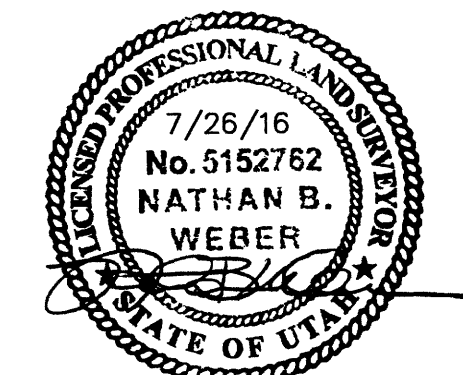

SALT LAKE VALLEY HEALTH DEPARTMENT APPROVED THIS <u>17</u> DAY OF <u>April</u> 20 <u>17</u> BY HEALTH DEPARTMENT. <i>Oliver Gray</i> DIRECTOR, SALT LAKE VALLEY HEALTH DEPARTMENT	COMCAST APPROVED THIS <u>31</u> DAY OF <u>January</u> 20 <u>17</u> BY COMCAST. <i>E. Valdez</i> COMCAST	CENTURYLINK APPROVED THIS <u>31</u> DAY OF <u>January</u> 20 <u>17</u> BY CENTURYLINK. <i>Beth Niki</i> CENTURYLINK	ROCKY MOUNTAIN POWER APPROVED THIS <u>31st</u> DAY OF <u>JANUARY</u> 20 <u>17</u> BY ROCKY MOUNTAIN POWER. <i>Paula</i> (ROCKY MOUNTAIN POWER)	SOUTH VALLEY SEWER DISTRICT APPROVED THIS <u>13</u> DAY OF <u>April</u> 20 <u>17</u> BY SOUTH VALLEY SEWER DISTRICT. <i>General Manager</i> GENERAL MANAGER	QUESTAR APPROVED THIS <u>3</u> DAY OF <u>February</u> 20 <u>17</u> BY QUESTAR GAS. <i>Jason Sander</i> QUESTAR	TABULATIONS 1. TOTAL PLAT ACREAGE 0.262 ACRES 2. TOTAL RIGHT-OF-WAY 0.000 ACRES 3. TOTAL OPEN SPACE 0.127 ACRES	DIAMOND LAND SURVEYING, LLC 5243 South Green Pine Drive Murray, Utah 84123 diamond@hdsurvey.com Phone (801) 266-5099 Fax 266-5032
CHECKED FOR ZONING ZONE <u>MU-2</u> AREA _____ WIDTH _____ NAME <u>Bryan</u> DATE <u>4-17-17</u>	PLANNING COMMISSION APPROVED THIS <u>19</u> DAY OF <u>April</u> 20 <u>17</u> BY THE HERRIMAN PLANNING COMMISSION. <i>Jessica Martin</i> CHAIRMAN, HERRIMAN PLANNING COMMISSION	HERRIMAN CITY MUNICIPAL WATER APPROVED THIS <u>19th</u> DAY OF <u>April</u> 20 <u>17</u> BY HERRIMAN CITY MUNICIPAL WATER. <i>[Signature]</i> HERRIMAN CITY	HERRIMAN CITY ENGINEER I HEREBY CERTIFY THAT THIS OFFICE HAS EXAMINED THIS PLAT AND IT IS CORRECT IN ACCORDANCE WITH INFORMATION ON FILE IN THIS OFFICE. <u>5/01/17</u> DATE <i>Beth Jones</i> HERRIMAN CITY ENGINEER	APPROVAL AS TO FORM APPROVED AS TO FORM THIS <u>2nd</u> DAY OF <u>May</u> 20 <u>17</u> <i>[Signature]</i> HERRIMAN CITY ATTORNEY 26-36-41	HERRIMAN CITY APPROVED THIS <u>2nd</u> DAY OF <u>May</u> 20 <u>17</u> BY HERRIMAN CITY. ATTEST: <i>[Signature]</i> CITY RECORDER MAYOR: <i>[Signature]</i>	SALT LAKE COUNTY RECORDER #12527985 STATE OF UTAH, COUNTY OF SALT LAKE RECORDED RECORDED AND FILED AT THE REQUEST OF: <u>Edge Homes</u> DATE: <u>5-3-2017</u> TIME: <u>12:06PM</u> BOOK: <u>2017P</u> PAGE: <u>100</u> FEE \$ <u>\$101.00</u> \$101.00 SALT LAKE COUNTY RECORDER 2017-130	

HORIZON HEIGHTS BUILDING 5P CONDOMINIUMS

LOCATED IN THE SOUTHEAST QUARTER
OF SECTION 36,
TOWNSHIP 3 SOUTH, RANGE 2 WEST,
SALT LAKE BASE AND MERIDIAN

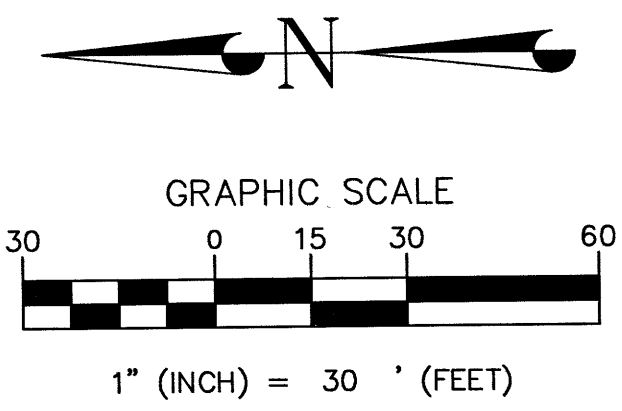
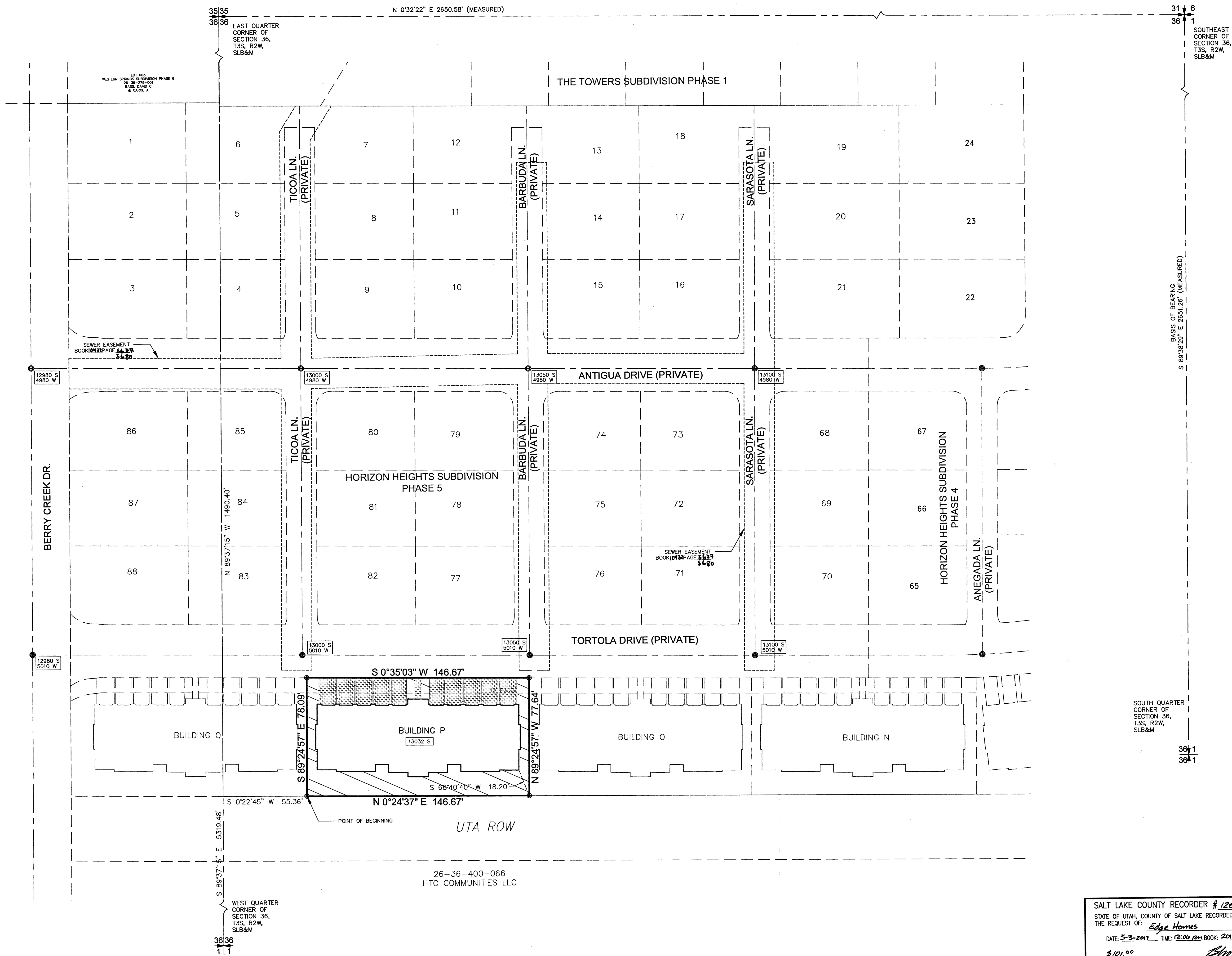

- LEGEND**
- Section Line
 - Boundary Line
 - Private Right of Way Line
 - Public Utility and Drainage Easement
 - Adjoiner Line
 - Sanitary Sewer Easement
 - Limited Common Area
 - Common Area and Public Utility Easement Maintained by HOA
 - Section Corner
 - Quarter Section Corner
 - Subdivision Corner
 - Centerline Monument

NO CITY MAINTENANCE ON PRIVATE STREETS

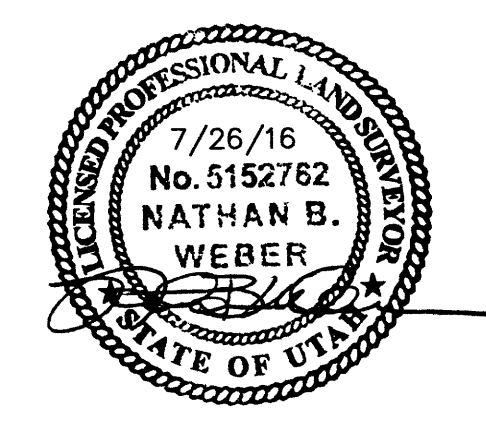

PREPARED BY:
DIAMOND LAND SURVEYING, LLC
5243 South Green Pine Drive
Murray, Utah 84123
office@diamondlandsurveying.com
Phone (801) 266-5099 Fax 266-5032

SALT LAKE COUNTY RECORDER # 12527985
STATE OF UTAH, COUNTY OF SALT LAKE RECORDED AND FILED AT THE REQUEST OF: *Edge Homes*
DATE: 5-3-2017 TIME: 12:06 PM BOOK: 2017P PAGE: 100
\$101.00
FEE \$
Blumen
SALT LAKE COUNTY RECORDER

HORIZON HEIGHTS BUILDING 5P CONDOMINIUMS

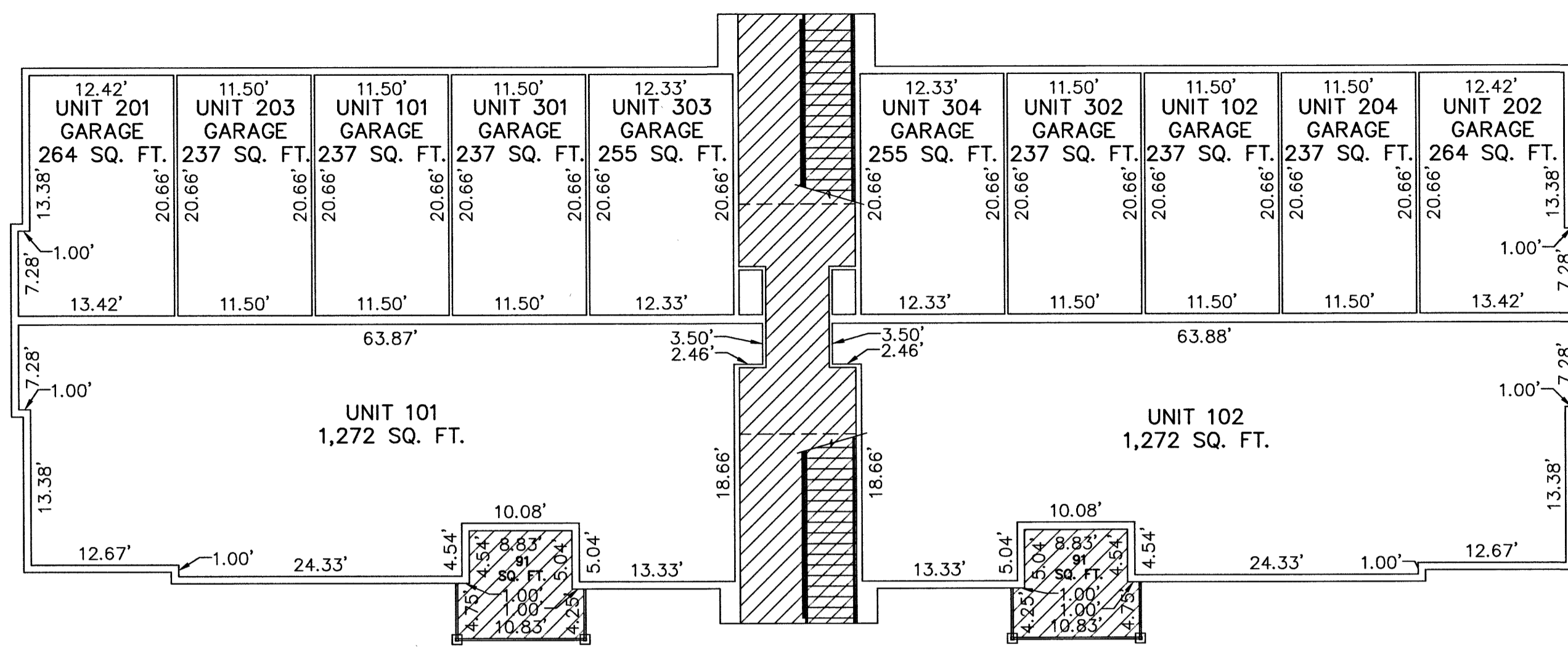

MAIN LEVEL

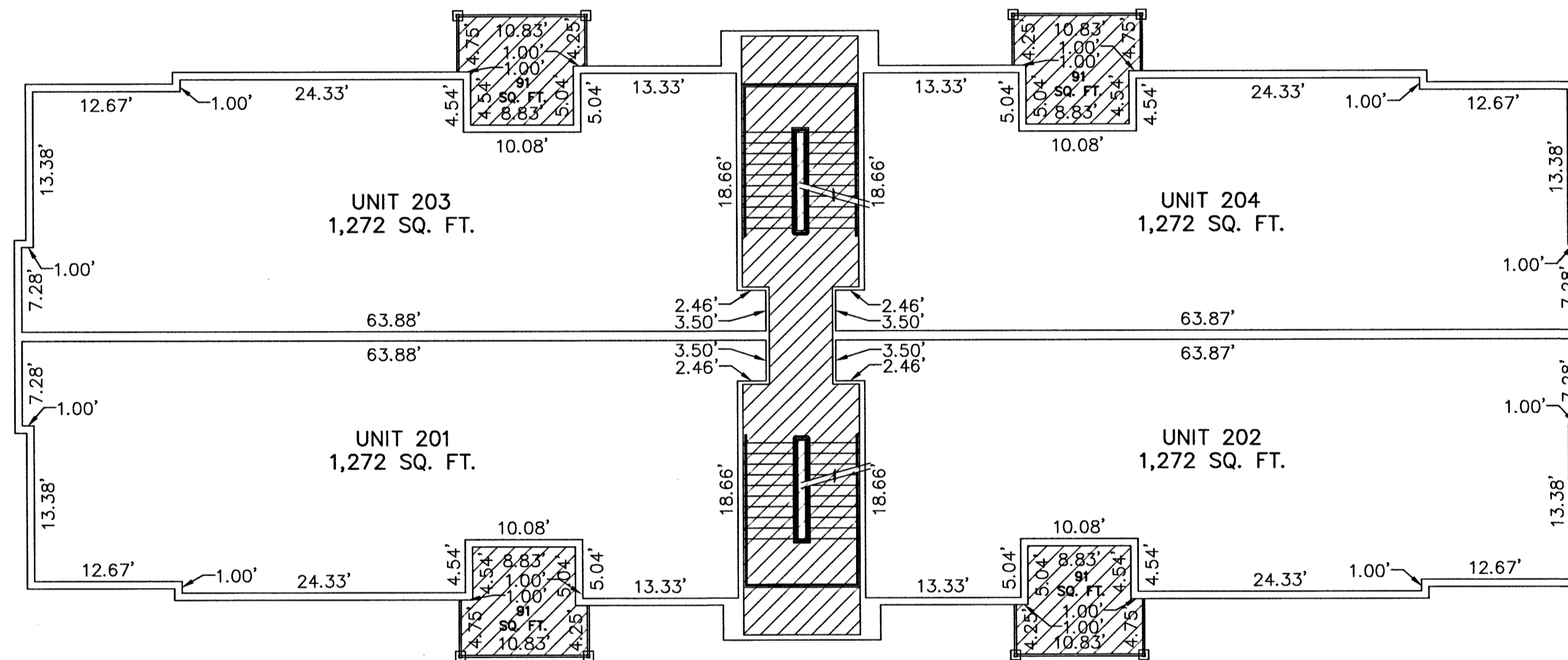

2ND LEVEL

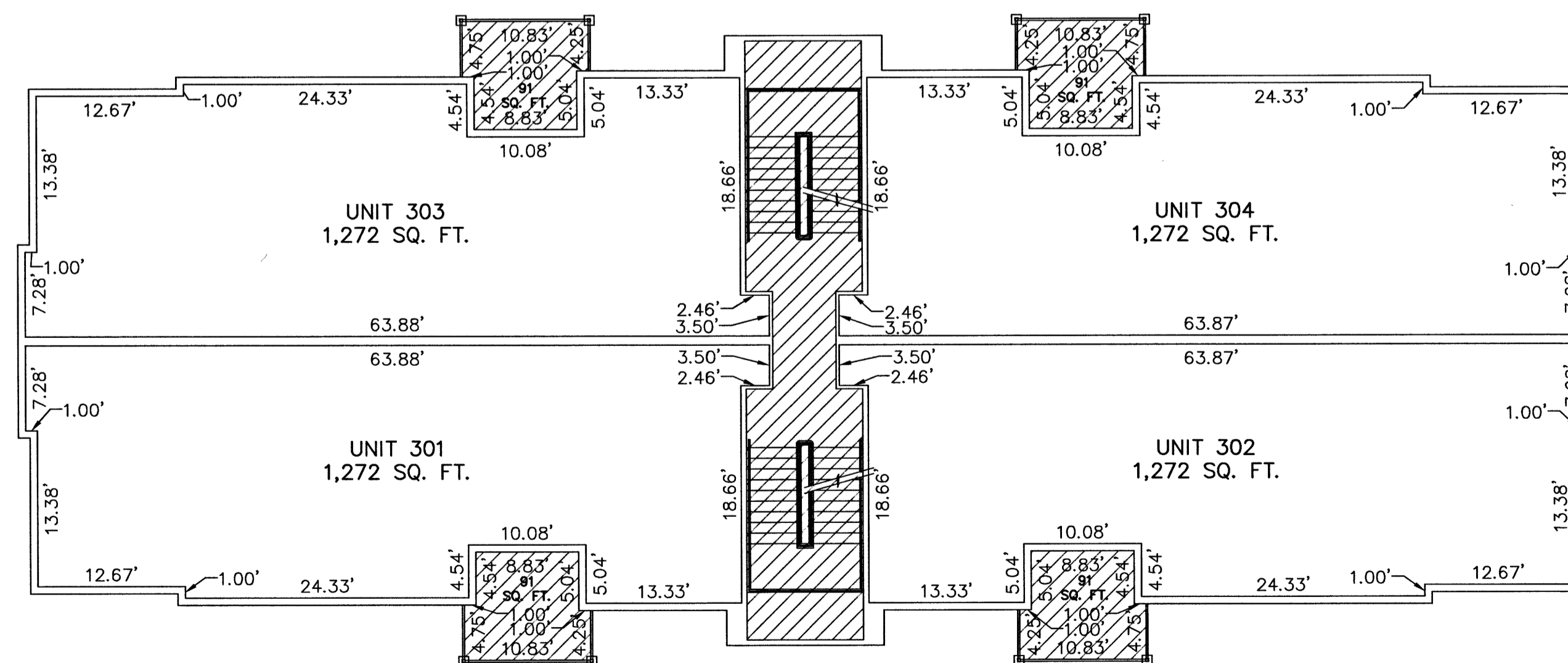

3RD LEVEL



FRONT ELEVATION

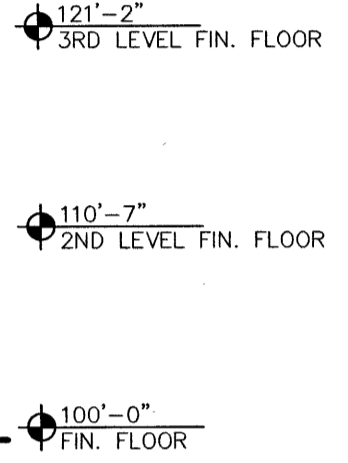
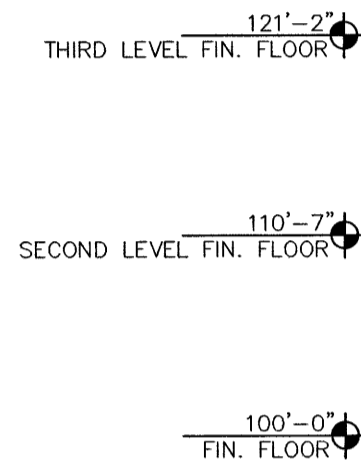

REAR ELEVATION

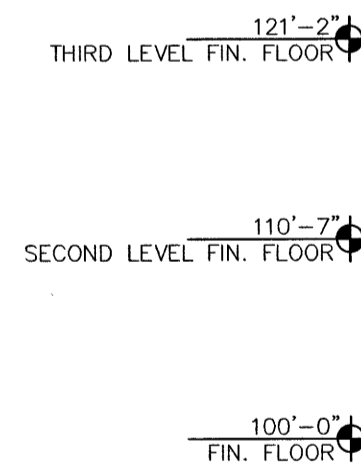

PREPARED BY:

DIAMOND LAND SURVEYING, LLC

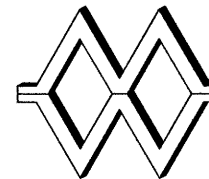

5243 South Green Pine Drive
Murray, Utah 84123
office@diamondlandsurveying.com
Phone (801) 266-5099 Fax 266-5032

GRAPHIC SCALE

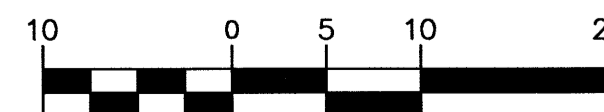

1" (INCH) = 10' (FEET)

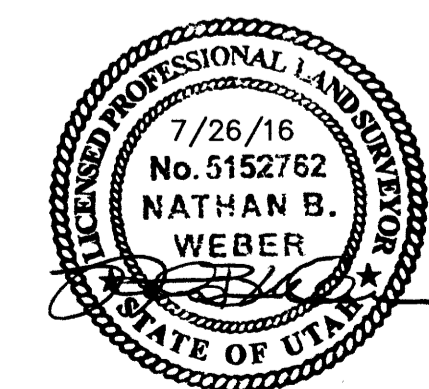

SHEET 2 OF 2

SALT LAKE COUNTY RECORDER # 12527985
STATE OF UTAH, COUNTY OF SALT LAKE RECORDED AND FILED AT THE REQUEST OF: *Edge Homes*
DATE: 5-3-2017 TIME: 12:06 PM BOOK: 2017P PAGE: 100
FEE \$ *310.00*
[Signature] Deputy SALT LAKE COUNTY RECORDER