

HORIZON HEIGHTS BUILDING 1C CONDOMINIUMS

LOCATED IN THE SOUTHEAST QUARTER
OF SECTION 36,
TOWNSHIP 3 SOUTH, RANGE 2 WEST,
SALT LAKE BASE AND MERIDIAN

SURVEYOR CERTIFICATE

In accordance with Section 10-9A-603 of the Utah Code, I, Nathan B. Weber, do hereby certify that I am a Professional Land Surveyor holding license number 5152762 in accordance with Title 58, Chapter 22 of the Professional Engineers and Professional Land Surveyors Licensing Act.

I further certify that on behalf of Diamond Land Surveying, LLC, I have completed a survey of the property described on the plat in accordance with Section 17-23-17 of Utah Code, and have verified all measurements, shown and have subdivided said property into lots and streets hereafter to be known as HORIZON HEIGHTS BUILDING 1C CONDOMINIUMS, and have placed monuments as represented on the plat.

BOUNDARY DESCRIPTION

A parcel of land located in the Southeast Quarter of Section 36, Township 3 South, Range 2 West, Salt Lake Base and Meridian described as follows:

Beginning at a point on the westerly right-of-way line of Andros Lane, said point being North 0°32'22" East 1319.56 feet along the Section Line and North 89°27'38" West 1612.41 feet from the Southeast Corner of Section 36, Township 3 South, Range 2 West, Salt Lake Base and Meridian and running

thence South 52°47'41" West 85.46 feet;

thence North 37°12'19" West 178.17 feet;

thence North 52°47'41" East 85.46 feet to the westerly right-of-way line of Andros Lane;

thence South 37°12'19" East 178.17 feet along said westerly right-of-way line to the point of beginning.

OWNER'S DEDICATION

Know all men by these presents that the undersigned owners of the hereon described tract of land, hereby set apart and subdivide the same into lots and streets as shown on this plat and name said plat

HORIZON HEIGHTS BUILDING 1C CONDOMINIUMS

and do hereby dedicate for perpetual use of the public all, street right-of-ways, lots and easements as shown on this plat as intended for Public use. Owners hereby agree to warrant and defend and save the City harmless against any easements or other encumbrance on a dedicated street which will interfere with the City's use, maintenance and operation of the street.



Edge Horizon Heights, LLC

Date 8/11/16

CONSENT TO DEDICATE

Know all men by these presents that the undersigned, being the Trustee under a Trust Deed of the real property described on the description at left and, having caused same to be subdivided into lots and/or public streets to be hereafter known as HORIZON HEIGHTS BUILDING 1C CONDOMINIUMS, does hereby dedicate for perpetual use of the public all parcels of land shown on this plat as intended for Public use.

Date _____

ACKNOWLEDGMENT

STATE OF UTAH)
):S.S.
COUNTY OF SALT LAKE)

ON THIS THE 11 DAY OF August, 2016, PERSONALLY APPEARED BEFORE ME, Nathan B. Weber, THE SIGNER OF THE FOREGOING INSTRUMENT, WHO DULY ACKNOWLEDGED TO ME THAT (S)HE IS A Member OF EDGE HORIZON HEIGHTS, LLC, A UTAH LIMITED LIABILITY COMPANY, AND IS AUTHORIZED TO EXECUTE THE FOREGOING AGREEMENT IN ITS BEHALF AND THAT HE OR SHE EXECUTED IT IN SUCH CAPACITY.





NOTARY PUBLIC
RESIDING AT: Levi, UT

ROCKY MOUNTAIN POWER STATEMENT

1. Pursuant to Utah Code Ann. § 54-3-27 this plat conveys to the owner(s) or operators of utility facilities a public utility easement along with all the rights and duties described therein.

2. Pursuant to Utah Code Ann. § 17-27a-603(4)(c)(ii) Rocky Mountain Power accepts delivery of the PUE as described in this plat and approves this plat solely for the purpose of confirming that the plat contains public utility easements and approximates the location of the public utility easements, but does not warrant their precise location. Rocky Mountain Power may require other easements in order to serve this development. This approval does not affect any right that Rocky Mountain Power has under:

(1) a recorded easement or right-of-way
(2) the law applicable to prescriptive rights
(3) Title 54, Chapter 8a, Damage to Underground Utility Facilities or
(4) any other provision of law.

SOUTH VALLEY SEWER DISTRICT STATEMENT

THE SIGNATURE OF SOUTH VALLEY SEWER DISTRICT ON THE THIS PLAT DOES NOT CONSTITUTE ANY GUARANTEE OF AVAILABILITY OF SANITARY SEWER TO THE PROPERTY OR ANY APPROVAL OF SEWER LINE FACILITIES. THE OWNER(S) OF THE PROPERTY MUST PROVIDE SATISFACTORY PLANS TO THE SEWER DISTRICT FOR REVIEW AND APPROVAL BEFORE CONNECTING TO THE DISTRICT'S SEWER SYSTEM AND WILL BE REQUIRED TO COMPLY WITH THE DISTRICT'S RULES AND REGULATIONS.

TRUSTEE ACKNOWLEDGMENT

STATE OF UTAH)
):S.S.
COUNTY OF SALT LAKE)

On the _____ day of _____, 20____, personally appeared before me _____ as Trustee of the _____ under trust instrument dated _____, who acknowledged to me that he or she executed it in such capacity with authority to do so

NOTARY PUBLIC
Residing at: _____







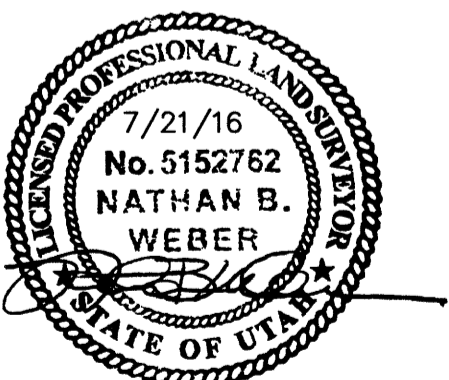

ACKNOWLEDGMENT

STATE OF UTAH)
):S.S.
COUNTY OF SALT LAKE)

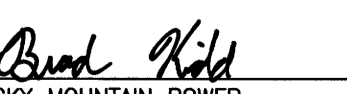
ON THIS THE _____ DAY OF _____, 2016, PERSONALLY APPEARED BEFORE ME, _____, THE SIGNER OF THE FOREGOING INSTRUMENT, WHO DULY ACKNOWLEDGED TO ME THAT (S)HE IS A _____ OF _____ A UTAH LIMITED LIABILITY COMPANY, AND IS AUTHORIZED TO EXECUTE THE FOREGOING AGREEMENT IN ITS BEHALF AND THAT HE OR SHE EXECUTED IT IN SUCH CAPACITY.

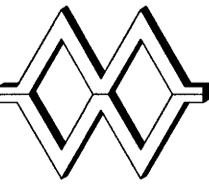
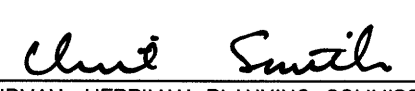
NOTARY PUBLIC
RESIDING AT: _____

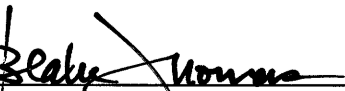
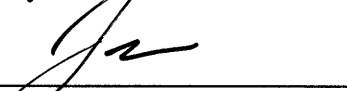

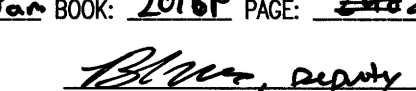
SALT LAKE VALLEY HEALTH DEPARTMENT APPROVED THIS <u>25TH</u> DAY OF <u>August</u> , 2016, BY HEALTH DEPARTMENT.  JEREMY ROBERTS SALT LAKE VALLEY HEALTH DEPARTMENT	COMCAST APPROVED THIS <u>11</u> DAY OF <u>Aug</u> , 2016, BY COMCAST.  E. VALDEZ COMCAST	CENTURYLINK APPROVED THIS <u>12</u> DAY OF <u>Aug</u> , 2016, BY CENTURYLINK.  BOB HILL CENTURYLINK	ROCKY MOUNTAIN POWER APPROVED THIS <u>11</u> DAY OF <u>Aug</u> , 2016, BY ROCKY MOUNTAIN POWER.  BRAD HILL ROCKY MOUNTAIN POWER	SOUTH VALLEY SEWER DISTRICT APPROVED THIS <u>24</u> DAY OF <u>August</u> , 2016, BY SOUTH VALLEY SEWER DISTRICT.  GENERAL MANAGER	QUESTAR APPROVED THIS <u>12TH</u> DAY OF <u>Aug</u> , 2016, BY QUESTAR GAS.  DEANNA ADKINS QUESTAR	TABULATIONS 1. TOTAL PLAT ACREAGE 0.349 ACRES 2. TOTAL RIGHT-OF-WAY 0.000 ACRES 3. TOTAL OPEN SPACE 0.171 ACRES	DIAMOND LAND SURVEYING, LLC  5243 South Green Pine Drive Murray, Utah 84123 diamond@hdsurvey.com Phone (801) 266-5099 Fax 266-5032
CHECKED FOR ZONING ZONE <u>MU-2</u> AREA _____ WIDTH _____ NAME <u>Bryan Mj</u> DATE <u>9-2-16</u>	PLANNING COMMISSION APPROVED THIS <u>29</u> DAY OF <u>August</u> , 2016, BY THE HERRIMAN PLANNING COMMISSION.  CHRIS SMITH CHAIRMAN, HERRIMAN PLANNING COMMISSION	HERRIMAN CITY MUNICIPAL WATER APPROVED THIS <u>31ST</u> DAY OF <u>August</u> , 2016, BY HERRIMAN CITY MUNICIPAL WATER.  HERRIMAN CITY ENGINEER	HERRIMAN CITY ENGINEER I HEREBY CERTIFY THAT THIS OFFICE HAS EXAMINED THIS PLAT AND IT IS CORRECT IN ACCORDANCE WITH INFORMATION ON FILE IN THIS OFFICE. DATE <u>9/13/16</u>  HERRIMAN CITY ENGINEER	APPROVAL AS TO FORM APPROVED AS TO FORM THIS <u>19</u> DAY OF <u>Sept</u> , 2016.  HERRIMAN CITY ATTORNEY	HERRIMAN CITY APPROVED THIS <u>22ND</u> DAY OF <u>Sept</u> , 2016, BY HERRIMAN CITY.  MAYOR	SALT LAKE COUNTY RECORDER # <u>12376529</u> STATE OF UTAH, COUNTY OF SALT LAKE RECORDED RECORDED AND FILED AT THE REQUEST OF: <u>EDGE HOMES</u> DATE: <u>9/29/16</u> , TIME: <u>2:48</u> AM, BOOK: <u>2016P</u> PAGE: <u>256</u> \$91.00 FEE \$  SALT LAKE COUNTY RECORDER	

HORIZON HEIGHTS BUILDING 1C CONDOMINIUMS

LOCATED IN THE SOUTHEAST QUARTER
OF SECTION 36,
TOWNSHIP 3 SOUTH, RANGE 2 WEST,
SALT LAKE BASE AND MERIDIAN

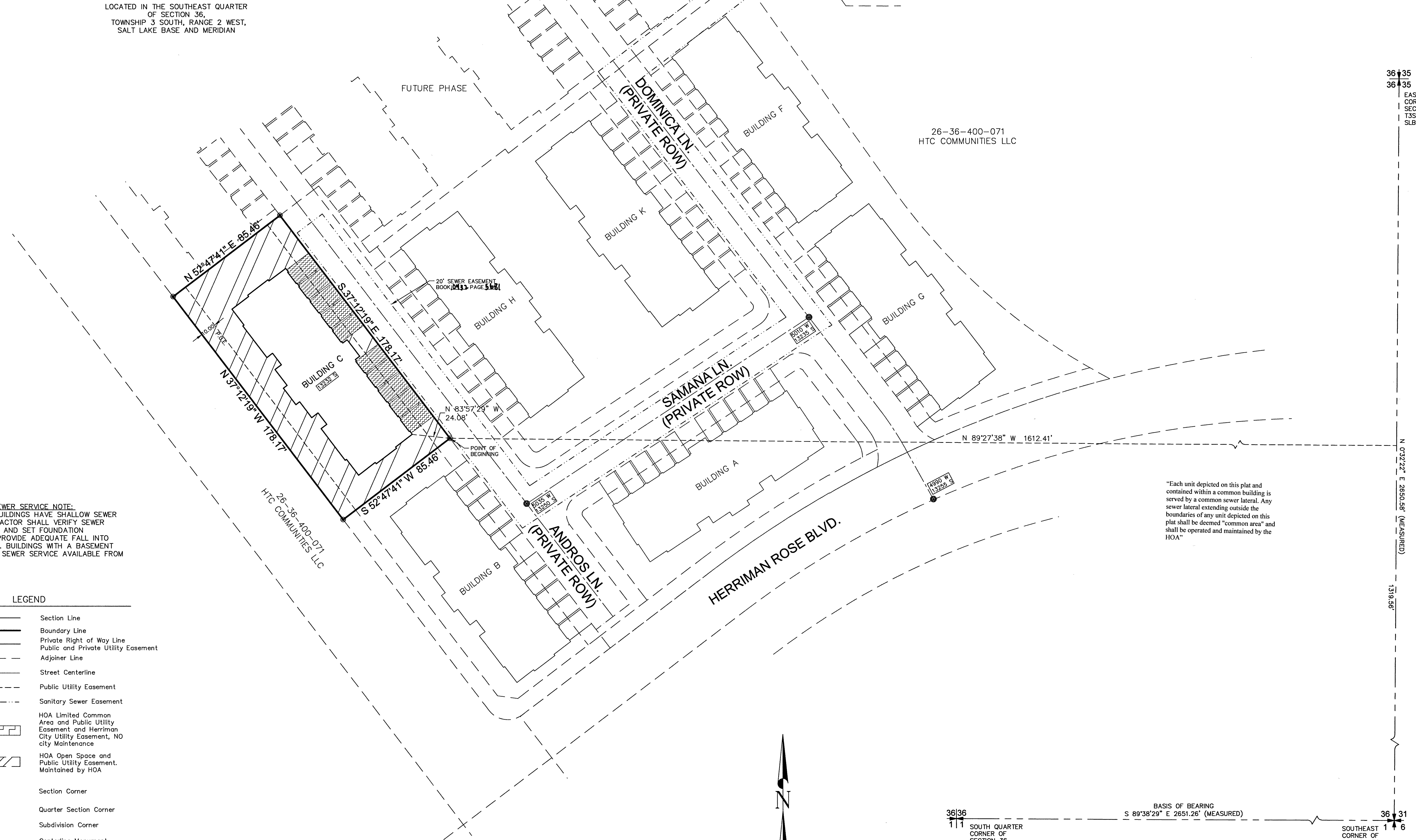

SEWER SERVICE NOTE:
ALL 10-PLEX BUILDINGS HAVE SHALLOW SEWER DEPTHS! CONTRACTOR SHALL VERIFY SEWER LATERAL DEPTH AND SET FOUNDATION ELEVATION TO PROVIDE ADEQUATE FALL INTO SEWER LATERAL. BUILDINGS WITH A BASEMENT MAY NOT HAVE SEWER SERVICE AVAILABLE FROM BASEMENT.

LEGEND

- Section Line
- Boundary Line
- Private Right of Way Line
- Public and Private Utility Easement
- Adjoiner Line
- Street Centerline
- Public Utility Easement
- Sanitary Sewer Easement
- HOA Limited Common Area and Public Utility Easement and Herriman City Utility Easement, NO city Maintenance
- HOA Open Space and Public Utility Easement. Maintained by HOA
- Section Corner
- Quarter Section Corner
- Subdivision Corner
- Centerline Monument

"Each unit depicted on this plat and contained within a common building is served by a common sewer lateral. Any sewer lateral extending outside the boundaries of any unit depicted on this plat shall be deemed "common area" and shall be operated and maintained by the HOA"

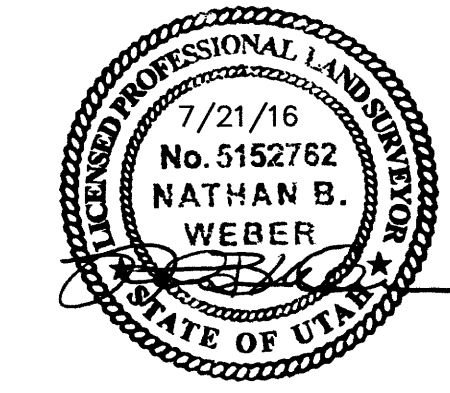
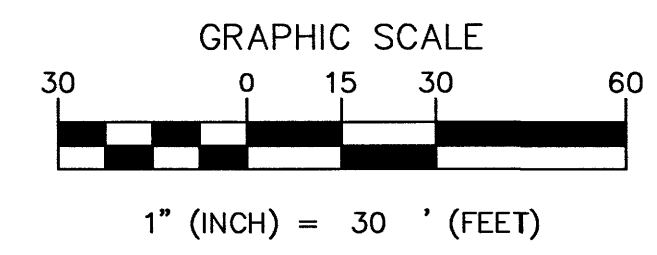

PREPARED BY:
DIAMOND LAND SURVEYING, LLC
5243 South Green Pine Drive
Murray, Utah 84123
office@diamondlandsurveying.com
Phone (801) 266-5099 Fax 266-5032

SHEET 2 OF 3

SALT LAKE COUNTY RECORDER # **12376589**
STATE OF UTAH, COUNTY OF SALT LAKE RECORDED AND FILED AT THE REQUEST OF: **EDGE HOMES**
DATE: **9/29/16** TIME: **8:40 am** BOOK: **20160** PAGE: **288256**
FEE: **\$91.00**
Nathan B. Weber
SALT LAKE COUNTY RECORDER

HORIZON HEIGHTS BUILDING 1C CONDOMINIUMS

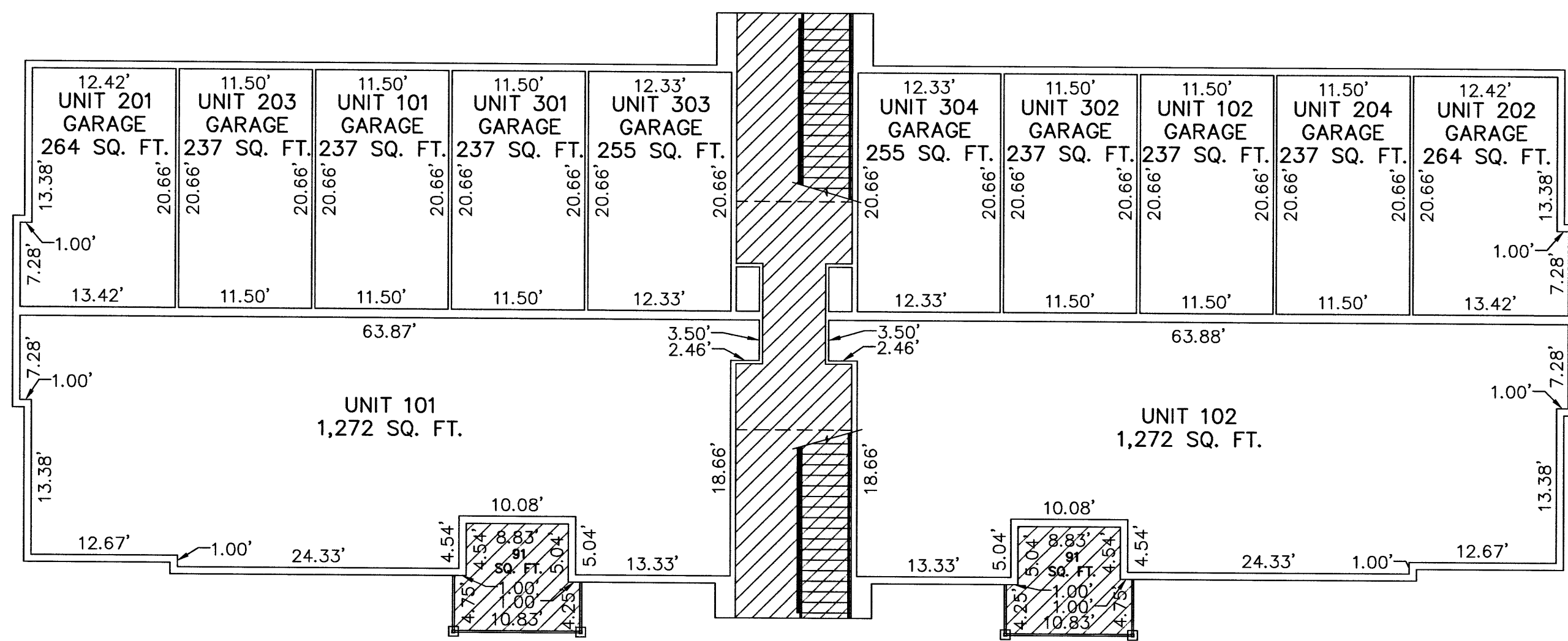

MAIN LEVEL

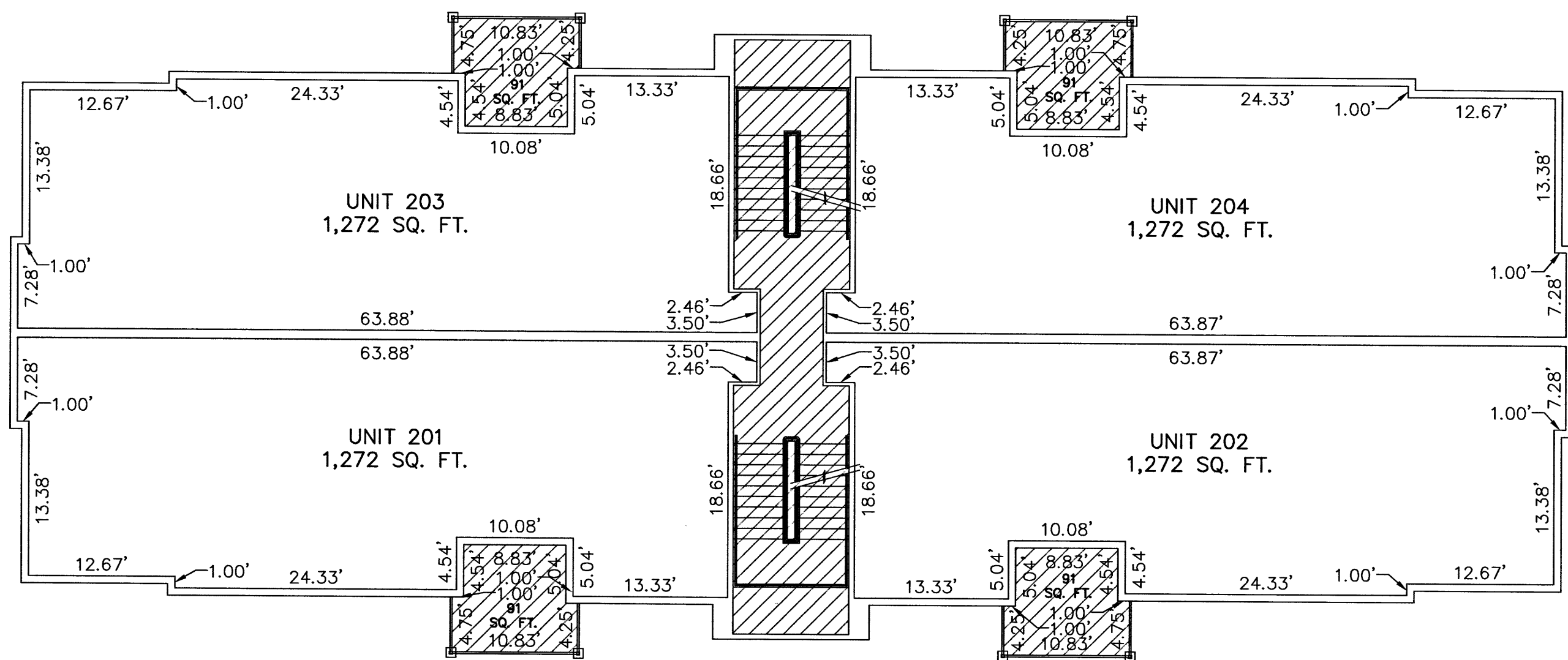

2ND LEVEL

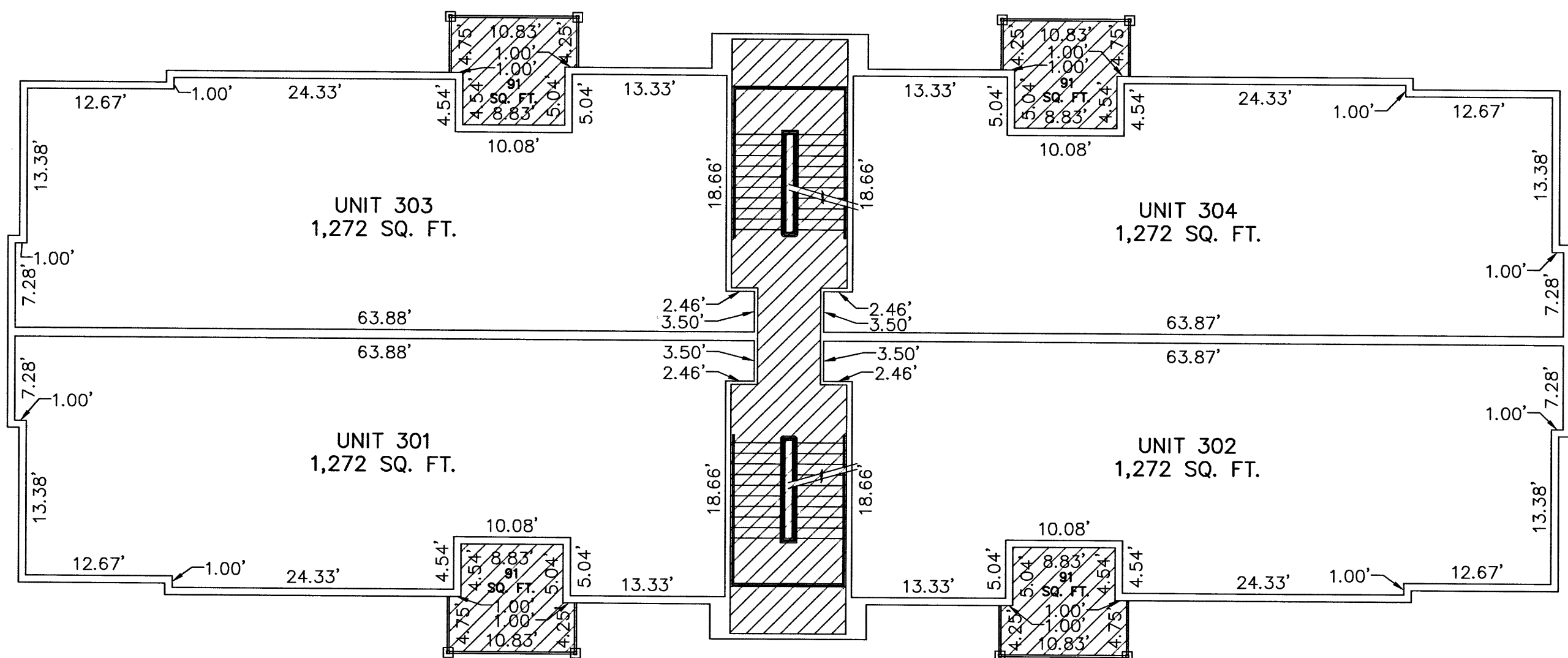

3RD LEVEL



FRONT ELEVATION



REAR ELEVATION

PREPARED BY:
DIAMOND LAND SURVEYING, LLC
 5243 South Green Pine Drive
 Murray, Utah 84123
 office@diamondlandsurveying.com
 Phone (801) 266-5099 Fax 266-5032

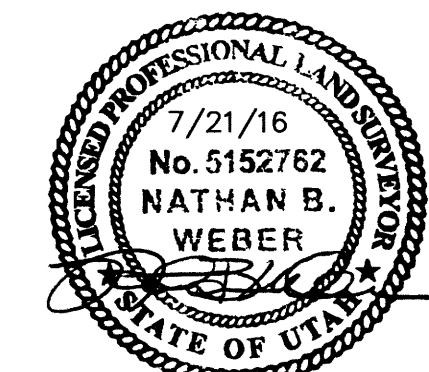
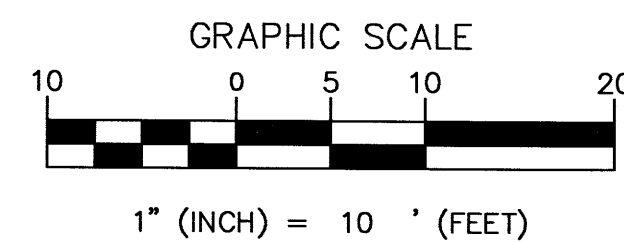

SHEET 3 OF 3
 SALT LAKE COUNTY RECORDER # **12376589**
 STATE OF UTAH, COUNTY OF SALT LAKE RECORDED AND FILED AT THE REQUEST OF: **EDGE HOMES**
 DATE: **9/29/16** TIME: **8:48** BOOK: **20160** PAGE: **256**
 \$91.00 FEE \$
 Deputy SALT LAKE COUNTY RECORDER